

STAINLESS STEEL CONTINUOUS BAND SEALER w/ 30MM SEAL WIDTH

Model: CBS-880-30MM

Extra Wide Sealing – 30mm (1")

Introducing our CBS-880 with a 30mm (1.18") seal width. This width is perfect for bags with a hang hole as the band sealer will seal below and above the hang hole to prevent any leakage. CBS-880 Right Feed Band Sealer is suitable for sealing all types of thermoplastic materials and bags. This sealer can be used in a variety of fields such as the food, medical, and cosmetic industries. Can seal 20-30 6" poly bags / minute.

Standard Features:

- Durable stainless steel construction
- Easy to operate – minimal operator training
- Fast warm up time
- No embossing capabilities
- Solid state digital temperature controller to maintain seal bars at proper temperature for consistent seal quality
- Fully adjustable conveyor (conveyor height and depth in relation to seal bars can be adjusted)
- Motorized rubber conveyor for speed control
- Knurled pressure rolls with variable pressure adjustment
- Sealing method – constant/direct heat accompanied with a pair each of cooling and heating blocks
- Can easily be converted to vertical configuration using an optional conversion kit (see picture below)
- Spare parts includes: PC Board, PTFE belt, wheel belt

Options:

- Stainless steel stand for horizontal model
- 15mm seal width
- Digital counter to keep track of sealed packages
- 220V Voltage

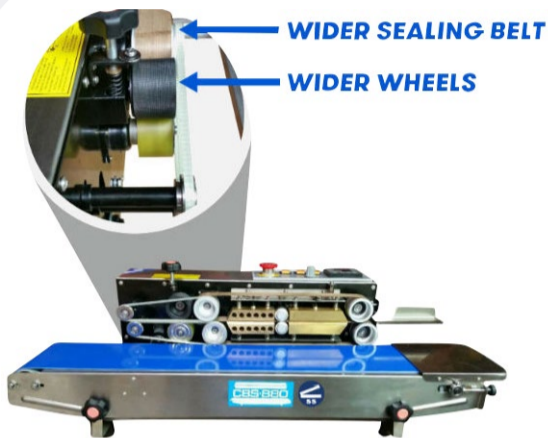

SPECIFICATIONS	
POWER	110V / 60Hz or 220V / 50Hz
MOTOR POWER	50W
SEALING SPEED	0-472 INCHES/MINUTE
SEAL WIDTH	30MM
TEMPERATURE RANGE	0-300°C
CONVEYOR SIZE	38" X 7"
SINGLE CONVEYOR LOAD	2.2LBS
MAX CONVEYOR LOAD	6.6LBS
BAG SIZE (FILLED)-VERTICAL UNIT	MINIMUM - 6" / MAXIMUM – 12"
DIMENSIONS	H: 33" X 17" X 13" / V: 33" X 17" X 22"



SCAN FOR INFO

STAINLESS STEEL CONTINUOUS BAND SEALER w/ 30MM SEAL WIDTH

Model: CBS-880-30MM

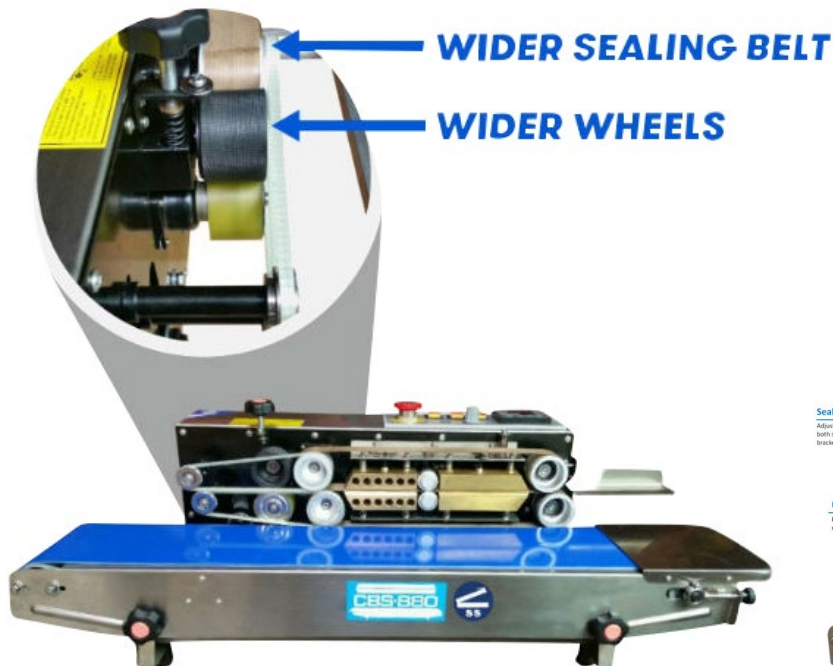

Option: Counter



Option: Extra Wide Conveyor



Option: Stainless Steel Stand (Horizontal Only)